

Specifications

Insulation Resistance:	500MΩ min. at 500 V DC
Contact Resistance:	35mΩ max. at 10mA / 20mV
Withstanding Voltage:	250 V AC for 1 minute
Operating Temperature Range:	-55°C ~ +85°C
Mating Cycles:	10 insertions max.

Materials and Finish

Housing:	Polyphenylenesulphide (PPS) resin, UL94V-0
Contact Base:	Copper Nickel Tin (CuNiSn)
Plating:	SnPb 2.0 – 4.0μm

Features

- ◇ Low profile SMT design with 2.5 mm height
- ◇ Outer lead forming makes visual inspection/repairing easier

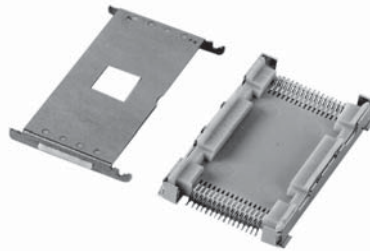

Part Number (Details)

IC197 – 32 02 – 2* * *

Series No.

No. of Contact Pins

Design No.

Style 200 = Metal Lid

Style 210 = PPS on Metal Lid

Packaging: 0 = Tray

1 = Tape & Reel

0 = Without Positioning Pin

1 = With Positioning Pin

Applicable Dimensions (Reference Only)

Outline Socket Dimensions

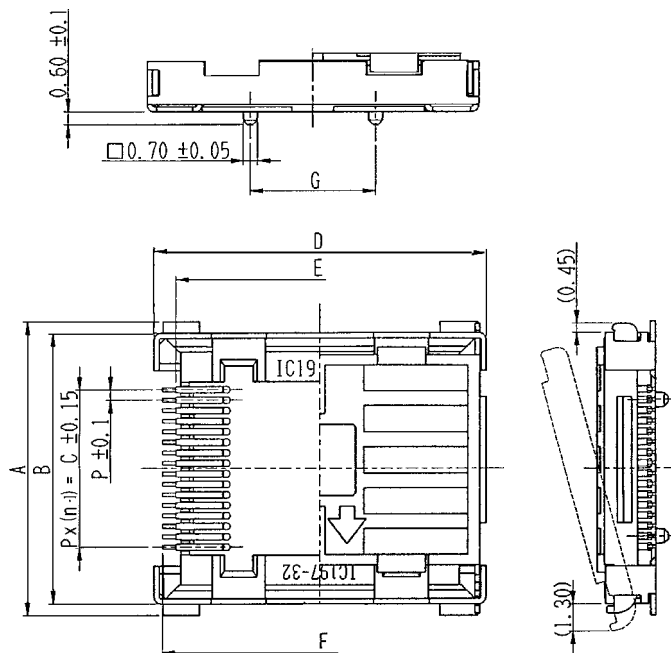

Socket Dimensions

For recommended IC and PCB-Layout Dimensions refer to tables on next page

Part Number	Pin Count	A	B	P x (n-1) = C	D	E	F	G	P
IC197-3202-2*0*	32	14.0	12.9	0.5x15=7.50	22.0	20.1	21.2	12.0	0.50
IC197-3203-2*0*	32	14.0	12.9	0.5x15=7.50	16.0	14.1	15.2	6.0	0.50
IC197-4001-2*0*	40	16.0	14.9	0.5x19=9.50	16.0	14.1	15.2	6.0	0.50
IC197-4004-2*0*	40	16.0	14.9	0.5x19=9.50	22.0	20.1	21.2	12.0	0.50
IC197-4807-2*0*	48	19.0	17.9	0.5x23=11.50	22.0	20.1	21.2	12.0	0.50
IC197-4807-2*10	48	19.0	17.9	0.5x23=11.50	22.0	20.1	21.2	12.0	0.50
IC197-5606-2*0*	56	21.0	19.9	0.5x27=13.50	22.0	20.1	21.2	12.0	0.50

Applicable Dimensions (Reference Only)

Recommended PCB Layout for Socket Style 200 and 210

Top View from Socket

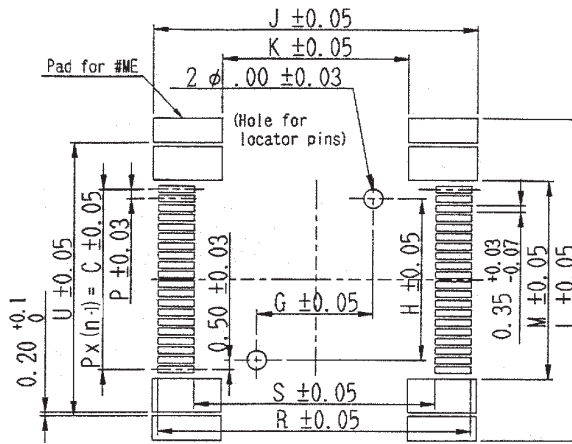

Part Number	G	H	J	K	L	M	P	P x (n-1) = C	R	S	U
IC197-3202-2*0*	12.0	6.50	23.0	15.70	15.0	8.45	0.50	0.50x15=7.50	22.40	18.60	12.40
IC197-3203-2*0*	6.0	6.50	17.0	9.70	15.0	8.45	0.50	0.50x15=7.50	16.40	12.60	12.40
IC197-4001-2*0*	6.0	8.50	17.0	9.70	17.0	10.45	0.50	0.50x19=9.50	16.40	12.60	14.40
IC197-4004-2*0*	12.0	8.50	23.0	15.70	17.0	10.45	0.50	0.50x19=9.50	22.40	18.60	14.40
IC197-4807-2*0*	12.0	10.50	23.0	15.70	20.0	13.30	0.50	0.50x23=11.50	22.40	18.60	17.40
IC197-4807-2*10	12.0	10.50	23.0	15.70	20.0	13.30	0.50	0.50x23=11.50	22.40	18.60	17.40
IC197-5606-2*0*	12.0	12.50	23.0	15.70	22.0	15.30	0.50	0.50x27=13.50	22.40	18.60	19.40

Recommended IC Dimensions for Socket Style 200 and 210

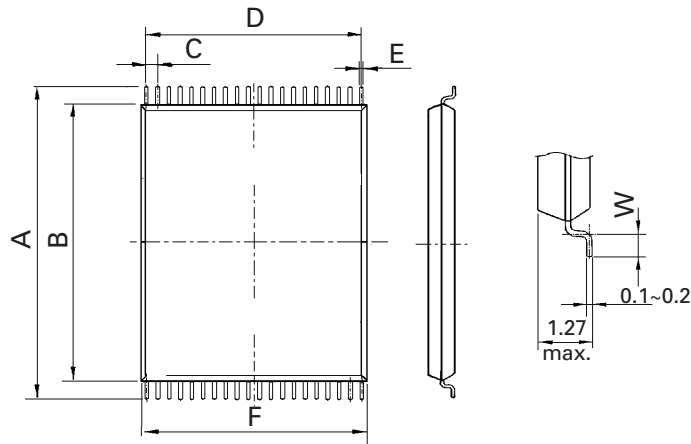

Part Number	A	B	C	D	E	F	W
IC197-3202-2*0*	19.8 - 20.2	18.3 - 18.5	0.50	7.50	0.15 - 0.30	7.8 - 8.2	0.3 - 0.7
IC197-3203-200*	13.8 - 14.2	12.3 - 12.5	0.50	7.50	0.15 - 0.30	7.8 - 8.2	0.3 - 0.7
IC197-4001-2*0*	13.8 - 14.2	12.3 - 12.5	0.50	9.50	0.15 - 0.30	9.8 - 10.2	0.3 - 0.7
IC197-4004-2*0*	19.8 - 20.2	18.3 - 18.5	0.50	9.50	0.15 - 0.30	9.8 - 10.2	0.3 - 0.7
IC197-4807-2*0*	19.8 - 20.2	18.3 - 18.5	0.50	11.50	0.15 - 0.30	11.8 - 12.2	0.3 - 0.7
IC197-4807-2*10	19.8 - 20.2	18.3 - 18.5	0.50	11.50	0.15 - 0.30	11.8 - 12.2	0.3 - 0.7
IC197-5606-2*0*	19.8 - 20.2	18.3 - 18.5	0.50	13.50	0.15 - 0.30	13.8 - 14.2	0.3 - 0.7